

ARCHIVED COPY: **S**
:em
DO NOT USE **al**



CONTENTS

CONVENTIONS USED IN THIS DOCUMENT	4
<i>Warning:</i>	4
<i>Caution:</i>	4
CONTACT INFORMATION	4
INTENDED USE/PURPOSE	5
INTENDED USER	5
TARGET POPULATION	5
CLINICAL BENEFIT	5
PLEASE NOTE:	5
INDICATIONS	5
CONTRAINDICATIONS	5
CYBERSECURITY	5
THE TORS SYSTEM	6
OVERVIEW	6
GENERATOR	6
<i>Front Panel</i>	6
<i>Rear Panel</i>	6
<i>TORS Transducers & Cables</i>	7
SAFETY 	8
WARNINGS	8
CAUTIONS	9
ELECTROMAGNETIC INTERFERENCE	9
COMPLICATIONS AND POTENTIAL SIDE-EFFECTS	10
SERIOUS INCIDENT	12
INSTRUCTIONS FOR USE	13
SETTING UP THE TORS SYSTEM	13
<i>Power up the Generator</i>	13
<i>Optional - Attach the "Cement" footswitch to the Rear Panel</i>	13
<i>Assemble the Cement Transducer + Probe (Applied Part) in the sterile field.</i>	13
<i>Cement Transducer - Connect</i>	14
<i>Cement Transducer - Initialise</i>	14

ARCHIVED COPY:

DO NOT USE

<i>Cement Transducer - Activate</i>	15
<i>Cement Removal – Irrigation</i>	16
<i>Fume Extraction</i>	16
<i>Performance Characteristics</i>	16
<i>Turn Off TORS</i>	16
FAULT / WARNING INDICATORS: (SEE ALSO APPENDIX 4: TONES AND BEEPS)	17
DECONTAMINATION	18
<i>After Use Re-Processing</i>	18
<i>Single Use Items</i>	19
<i>Reusable Items</i>	19
MANUAL CLEANING	19
AUTOMATED CLEANING	19
CLEANING INSPECTION	19
WRAPPING	20
STERILIZATION	20
<i>End of Life Management</i>	20
<i>Opened in Error</i>	20
<i>Cleaning the Generator</i>	20
<i>Cleaning the Footswitch</i>	20
EQUIPMENT CARE	21
<i>Probe Inspection</i>	21
<i>Transducer / Probe Usage</i>	21
<i>Storage of Equipment between Cases</i>	21
<i>Maintenance</i>	21
<i>Technical Support</i>	21
APPENDICES	22
APPENDIX 2: MARKINGS ON THE TORS FRONT AND BACK PANELS	28
APPENDIX 3: LABELLING SYMBOLS GLOSSARY	30
APPENDIX 4: ELECTROMAGNETIC INTERFERENCE	37
APPENDIX 5: TONES AND BEEPS	39
APPENDIX 6: REAR PANEL MESSAGES	40
APPENDIX 7: TECHNICAL SPECIFICATION	40
APPENDIX 8: WARRANTY STATEMENT	41

ARCHIVED COPY:

DO NOT USE

Conventions used in this document

Warning:



A statement that if not strictly followed could result in injury or loss of life, or a statement that is otherwise required to be a warning.

ARCHIVED COPY:

Caution:

A statement that if not strictly followed could result in damage to the equipment

DO NOT USE

Contact Information

If the unit requires repair please contact us through your local supplier or directly:

Manufacturer:

Radley Scientific Ltd.
Bremridge House
Bremridge
Ashburton
Devon
TQ13 7JX
UK

Email: enquiries@tors.co.uk

Phone: +44 (0)1364 653899

Website: www.tors.co.uk

Intended Use/Purpose

TORS is an ultrasonic surgical device intended to be used for removal of polymethylmethacrylate (PMMA) bone cement in orthopaedic applications.

Intended user

TORS is intended to be used by surgical staff experienced with the operation of ultrasonic devices for cement removal, in a professional clinical setting. See relevant Warnings.

Target Population

There are no specific restrictions based on age, weight, health status or ethnicity. No specific patient populations have been defined but patients with contraindication are to be excluded, see Contraindications.

Clinical Benefit

- During treatment with TORS, the patient benefits from ultrasound bone cement removal.
- **TORS is a state-of-the-art device for efficient cement removal in orthopaedic revision surgeries.** It provides clinical benefit over mechanical cement removal methodologies through reduced risk of perforation compared to conventional **mechanical** methods in hip. It may also be used in knee, elbow and shoulder.

Please note:

- This document does not reference surgical techniques.
- The safety & effectiveness of any ultrasonic surgical equipment is mostly dependent upon the surgeon and nursing staff.

Indications

TORS is indicated for use in the removal of polymethylmethacrylate (PMMA) bone cement in orthopaedic applications.

Contraindications

- Do not use, if in the judgment of the surgeon, the use of ultrasonic surgical techniques is not in the best interest of the patient.
- Do not use for incising bone.

Cybersecurity

Neither the generator nor any other component accessory of this device can be connected to an external network of any kind; no external connection ports of any type are provided upon the generator. In this context no minimum hardware requirement exists, since the user has no ability to gain unauthorized access to the firmware.

Please read all Warning & Cautions contained in this document



Figure 3: TORS Cement Transducer

DO NOT USE



Figure 4: Cement Cable

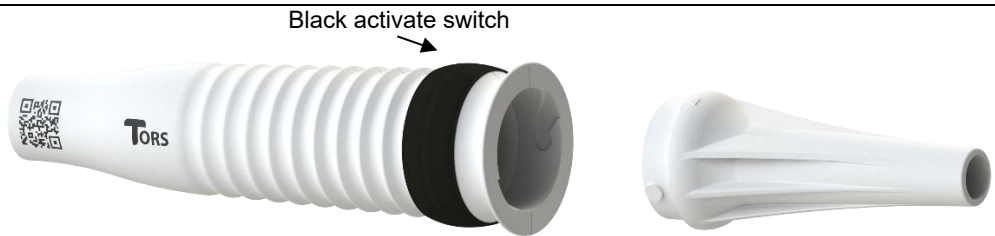

Figure 5: – Axial Grip Handpiece



Figure 6: – Axial Grip Handpiece with Cement Transducer, Probe, and Cement Cable fitted

See Appendix 1 for a full list of part numbers.

Safety

Warnings

- This device should only be used by surgeons who are (1) trained in the types of surgical procedures that are to be carried out and (2) trained in the specific use of ultrasonic surgical instruments.
- Do not operate TORS in a potentially explosive or flammable area, or in oxygen rich environments. Note that if the Probe touches anything metal while active, sparks may be produced.
- The use of TORS in cases where a patient or an operator of the unit has been fitted with a cardiac pacemaker is left to the discretion of the consultant in charge of the procedure although no electrical flow is made through or into the patient and many clinical papers on the use of ultrasound in the proximity of cardiac pacemakers have been published.
- Appropriate protective measures, including smoke evacuation, should be taken to protect users from any smoke, or other aerosols produced by the use of surgical ultrasound.
- Use extreme caution when using in the vicinity of nerves.
- Handle reusable parts correctly in order to achieve full service-life.
- Do not attempt to modify the acoustics. No modification of this equipment is allowed.
- The use of transducers or handpieces not supplied as part of the TORS system may damage the Generator and create a safety hazard for the operator and patient.
- Avoid touching or holding the probe tip at the end of the active probe. Danger of burns!
- Other than the active tip, do not allow probe to be in contact with tissue.
- Irrigate the femoral canal after each activation.
- If the probe is deactivated inside heated PMMA it is possible the cooling cement will adhere very strongly to the probe, in which case it may become difficult to reactivate the probe in order to remove it from the cement.
- When guiding the TORS Cement Probe through PMMA, care must be taken not to exert excessive force in order to maintain control of the direction of travel of the probe.
- Use of excessive force in vicinity of thin bone may cause perforation.
- Avoid resting the hot probe tip on skin or other tissue for at least 60 s after cessation of energizing as it will have become hot while cutting. (User may quench hot probe tip in saline.)
- Care should be taken when in contact with tissue between activations, in case accidental activation should occur.
- If the probe comes into contact with bone, using recommended cooling strategies a bone temperature of up to 51°C may be seen.
- Allowing active tip to contact bone may cause damage to the bone.
- Wherever possible avoid contact between the side of active cement probe and patient tissue.
- Mains isolation is achieved by use of the double pole switch located on the rear panel. DO NOT position the equipment in such a way as to make access to this disconnection switch difficult.
- To avoid the risk of electric shock, this equipment must only be connected to a main's supply with protective earth.
- TORS is not MRI safe or MRI compatible.
- Do not re-sterilize or reuse any single use parts.
- Portable RF communications equipment (including peripherals such as antenna cables and external antennas) should be used no closer than 30 cm (12 inches) to any part of TORS, including cables specified by RSL. Otherwise, degradation of the performance of this equipment could result.
- TORS should not be used adjacent to or stacked with other equipment. If adjacent or stacked use is necessary TORS should be observed to verify normal operation in the configuration in which it will be used.
- The use of accessories, transducers and cables other than those specified may result in increased emissions, decreased immunity or improper operation.
- There are no user serviceable parts.
- Do not combine multiple extension bars, only use one extension bar per cement probe and transducer.
- When attaching cement probes to the cement transducer, do not OVER-TIGHTEN the probe, a firm pressure applied with both spanners, is all that is required.

Cautions

- U.S. law restricts this device to sale by or on the order of a licensed physician.
- The nursing staff must be trained so that they are familiar with the equipment to be used.
- Before any sterile packed (single use) accessory for TORS is opened, it must be inspected for packaging integrity. The outer carton may be dented, crumpled or even punctured so long as the sealed pouch inside is not punctured. If a bend or wrinkle in the pouch makes a puncture likely DO NOT OPEN/USE but return to manufacturer.
- Avoid allowing an active probe to come into contact with any metal surface. Any damage increases the risk of fatigue, which might result in tip detachment from the probe.
- Do not sterilize the TORS generator or footswitch.
- Do not allow the generator to enter the sterile field in theater.
- Do not block or otherwise restrict the vents on the rear and bottom panels of the generator.
- Never allow electrosurgical equipment to contact the probe.
- Do not spill any liquid upon the generator.
- Ensure that more than one single use axial-grip handpiece is available in case of accidental contamination.
- Always transport TORS using the supplied transport cases.
- The TORS generator has an Equipotential Terminal on the back panel. This is provided for compatibility with other medical systems requiring such connections. This conductor is not intended for protective earthing. Refer to EN 60601-1 for details of use with ME Systems.
- TORS:
 - i. should be used only for those procedures for which it is indicated.
 - ii. should be used with an appropriate power level commensurate with the required task.
 - iii. should be used with correct surgical technique.

If used correctly the TORS should remove PMMA cement to the satisfaction of the user.

The equipment should inform the user of its status either by audio or visual means, unless ultrasound output is not possible. However, if a fault with the audio or visual indicators occurs whilst a cut is in progress, it may allow that cut to be completed without indication.

Electromagnetic Interference

- This equipment is only suitable for use in hospital operating theatre / operating room.
- The performance of TORS may be degraded if it is subjected to electromagnetic disturbances e.g. an incorrect display that clears automatically once activate switch is pressed/depressed.
- Do not use TORS simultaneously with laser equipment or high frequency surgical equipment.
- This equipment has been tested and found to comply with the limits for a medical device.

However should interference occur, the user can try the following measures:-

1. Turn equipment off and on to confirm the source of the interference.
 2. Increase separation between this equipment and other devices.
 3. Connect this equipment to a power socket different from that to which the other devices are connected.
 4. Consult medical physics department.
- The EMISSIONS characteristics of this equipment make it suitable for use in industrial areas and hospitals (CISPR 11 class A). If it is used in a residential environment (for which CISPR 11 class B is normally required) this equipment might not offer adequate protection to radio-frequency communication services. The user might need to take mitigation measures, such as relocating or re-orienting the equipment.
 - Where replacement transducers and cables are required, these must be manufactured by RSL (see Appendix 2 for full listing),
 - See also

- Appendix 4: Electromagnetic Interference.

Complications and Potential Side-effects

General risks and complications of arthroplasty surgery

- Bone loss during prosthesis and/or cement removal
- Cortical perforation
- Fracture in the bone around the artificial joint
- Recovery time, pain and potential for arthritis associated with deliberate osteotomy
- Nerve/vascular lesions
- Rebleeding or haematoma / seroma
- Ligament, artery or nerve damage in the area around the knee joint
- Blood clots or deep vein thrombosis or pulmonary embolism
- Haemorrhage caused by tissue injury or ineffective haemostasis
- Bone/joint infection
- Late infection
- Infection of the wound and/or the tissue around the artificial joint
- Thromboembolism
- Implants or metal parts remaining in joint
- Fatigue fracture
- Excess bone forming around the artificial joint (knee) restricting movement
- Excess scar tissue forming and restricting movement
- Kneecap or hip dislocation
- Numbness in the vicinity of the wound scar
- Loosening of the artificial joint (normally after 10-15 years)
- Joint wear and tear
- Joint stiffening
- Bone cement implantation syndrome
- Hypoxia
- Hypotension
- Cardiac arrhythmias
- Cardiovascular collapse
- Thermal injury due to cement polymerization (setting) reaction
- Contact inhalational exposure to PMMA monomer leading to hypersensitivity
- Asthmatic reactions
- Neurological symptoms
- Localized irritation
- Personal risks from anesthetic or the surgery itself

Potential side-effects of ultrasonic arthroplasty surgery

- Necrosis and clinical dysfunction in femoral cortex and surrounding soft tissue due to heat transmission from ultrasonic probe/cement interface
- Intramedullary canal perforation
- Different tissues and bone cement will be heated to different degrees with the same ultrasound parameters
- Each cell type has a different susceptibility to thermal injury

- Pathologic humeral fracture
- Microscopic bone cracks
- Plume production (95% water, 5% cell debris)
- Nerve palsy
- Risk of cross-infection from re-sterilized reusable parts of the system
- Weakening of the remaining cortical bone
- Incomplete extraction of the cement
- Cement removal occurs more slowly than expected

ARCHIVED COPY:

DO NOT USE

Serious Incident

The Medical Device Regulation defines a serious incident as:

“...any incident that directly or indirectly led, might have led or might lead to any of the following:

(a) the death of a patient, user or other person,

(b) the temporary or permanent serious deterioration of a patient's, user's or other person's state of health

(c) a serious public health threat”

In the event that a serious incident occurs in relation to the TORS device, the user and/or patient should report the serious incident to the Manufacturer and to the Competent Authority of the state in which the user and/or patient is established.

ARCHIVED COPY:

DO NOT USE

Instructions for Use

Note. Neither the generator nor any other component accessory of this device can be connected to an external network of any kind; no external connection ports of any type are provided upon the generator. In this context no minimum hardware requirement exists, since the user has no ability to gain unauthorized access to the firmware.

Setting Up the TORS System

Remove the protective film from the generator front panel, if it remains attached.

Power up the Generator

- Connect the mains lead to the rear panel of the Generator.
- Press the Mains rocker switch up, "I", to switch on.
- The Generator will now power up with an audio indicator flourish of tones, conduct a brief full screen illumination test as shown in **Error! Reference source not found.**

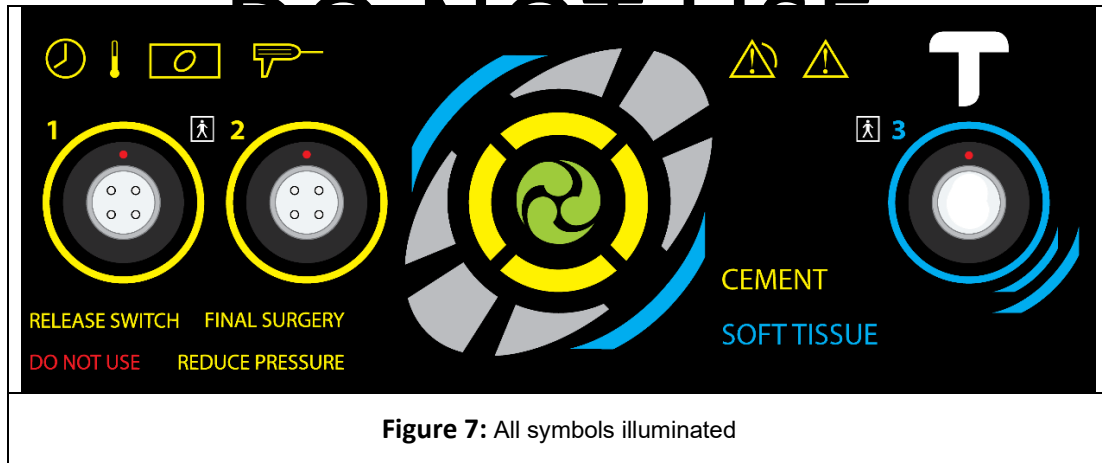

- After approximately one second the display will show:

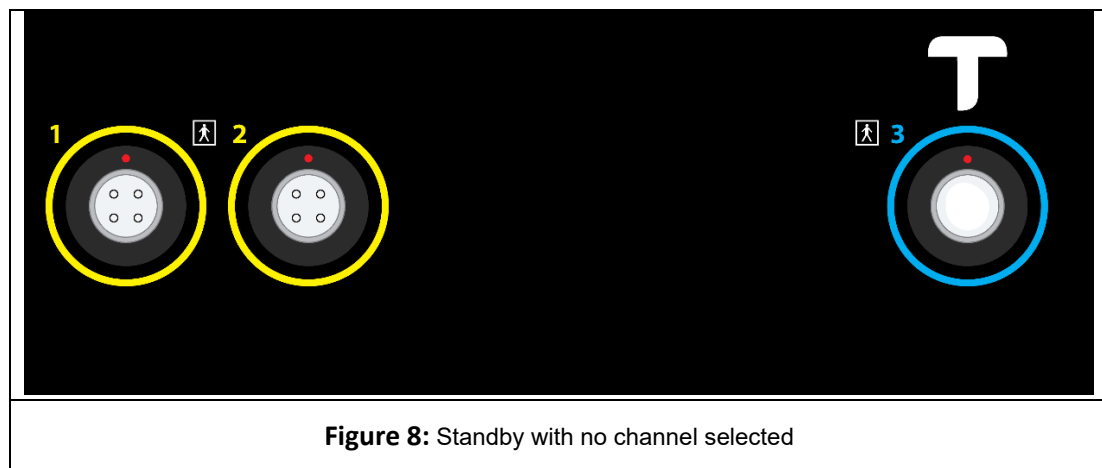

Note: The text and symbols in blue are not used during operation.

Optional - Attach the "Cement" footswitch to the Rear Panel

- The tube with the **Yellow** + "1" collar attaches to the similarly marked connection.
- The tube with the **Yellow** + "2" collar attaches to the similarly marked connection.

Assemble the Cement Transducer + Probe (Applied Part) **in the sterile field.**

- From the pre-sterilized instrument tray select the cement transducer.
- From the pre-sterilized instrument tray select the appropriate probe.
- Outside the sterile field, open the carton of the sterile axial-grip handpiece (single use) and remove pouch containing the tray+lid. Open the pouch and offer the tray+lid into the sterile field. Inside the sterile field, open the tray+lid and remove the handpiece grip and sleeve.

- Fit the transducer into the handpiece. Rotate the transducer and drop into place – ensure that it is securely connected. See (1) & (2) in **Error! Reference source not found.**Figure 9 below.
- Slide the handpiece sleeve over the Transducer horn. Locate the lugs at the base of the sleeve into the handpiece grip and twist / click into place. See (3) below.
- Using both supplied spanners, attach the probe to the transducer (4) & (5) below.
- **ALWAYS** use **BOTH** spanners for tightening the probe to avoid damaging the cement transducer.
- **Do not OVER-TIGHTEN** the probe.

ARCHIVED COPY:

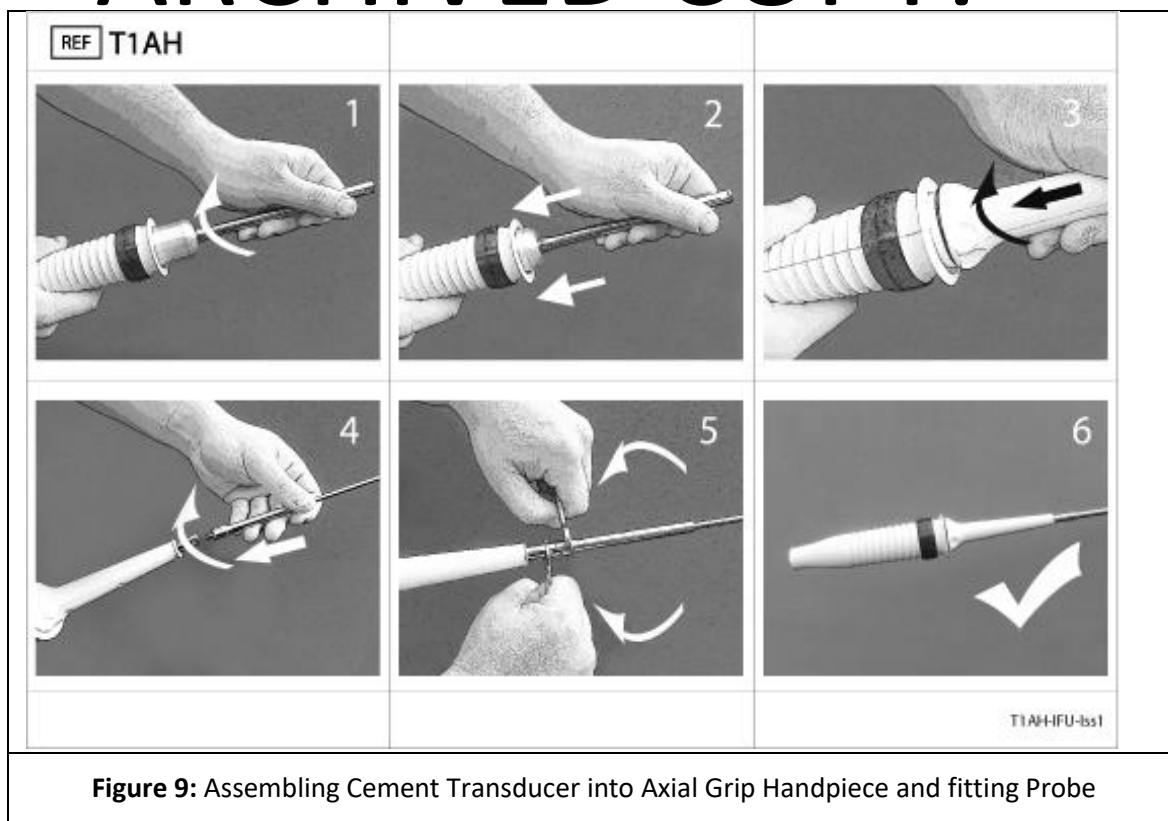

Cement Transducer - Connect

- Connect the Cement cable (Yellow coding to Generator Channel 1 or 2 (Yellow rings) by aligning the red dot on the metal plug with the red dot on the Generator socket. Push the plug into the socket until it clicks.
- Connect the other end of the Cement cable (Plastic connector) to the Cement handpiece. Align the arrow on the plastic connector with the spaces separating the two slots in the rear connector on the axial-grip handpiece. Click into place.
- To remove, pull back on the knurled part of the plug - **Do not** pull the cable.

Cement Transducer - Initialise

- When the surgeon is ready to use the transducer, they must initialize it to enable power. This is done simply by pressing the black activate button on the handpiece or the yellow footswitch (Ch1 or Ch2). The display shows:

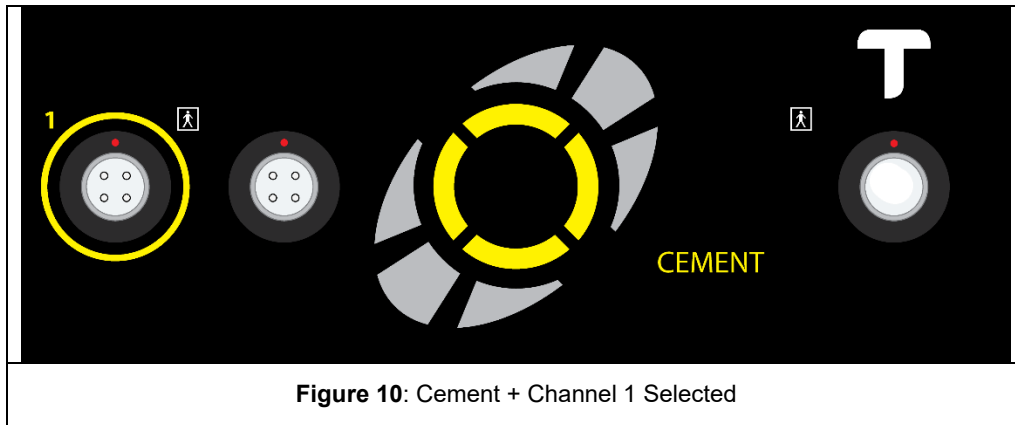

Figure 10: Cement + Channel 1 Selected

DO NOT USE

Cement Transducer - Activate

- Press the black activate button on the Handpiece or the yellow Footswitch. This will activate the Transducer and Probe for surgery. An audible indicator signifies power delivery with a continuous low-pitched tone.

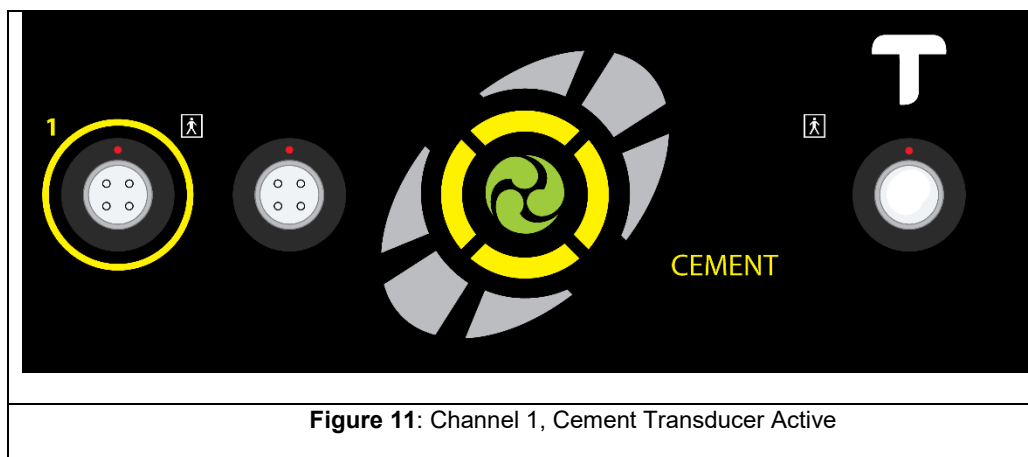

Figure 11: Channel 1, Cement Transducer Active

- To stop output, release the Footswitch or activate button.
- If the Footswitch or activate button is held down continuously for 20 seconds the audio indicator sound will change from continuous to pulsed.
- After a further 5 seconds the Generator will terminate power.
 - Output power is cut
 - Audible indicator stops
 - Displays Warning symbol + Transducer symbol + Clock symbol.
- These will remain illuminated as long as the Footswitch or activate button is pressed.
- When it is released, normal operation resumes

Cement Removal – Irrigation

It is important to irrigate the bone canal during the cement removal process for two reasons:- It clears the canal of cement debris, including dust, and it also helps maintain safe operating temperatures within the canal. Such irrigation systems are standard provision in orthopaedic cases.

It is recommended that irrigation in the form of pulsed lavage or manual irrigation is used after each activation of any probe-type, piercer or scraper.

Do not irrigate *during* an activation as this may compromise the efficacy of the ultrasound transmission, translating to a slower cement removal process. The TORS probe are designed to produce rapid heating at the probe / PMMA interface, thus softening the cement. Any cooling during this process will impede the desired effect.

Any waste products should be disposed of as per normal hospital procedures.

Fume Extraction

It is recommended that a suitable extraction system is used to remove smoke, aerosols and any associated odors.

Any waste products should be disposed of as per normal hospital procedures.

Performance Characteristics

- Cement Removal

The different diameters of piercer probes will penetrate cement at different rates but the size range allows access into varying open cement canal diameters with consequent varying volumes of cement removed per “cut”.

Likewise, the different scraper probe sizes will remove varying volumes of material per “cut”.

The 4 mm piercer (P4R2) is intended specifically for penetrating hard, High-Density Polyethylene (HDPE), cement restrictors (distal plugs). It has no proximal cement trapping flange and will not remove material. Once an initial hole has been made larger piercers and scrapers can be used to erode and remove the plug. It is not recommended for use on the softer, PMMA, or gelatine, distal plugs.

The user should not apply excessive force, but instead, allow the ultrasound to advance the probe through the cement.

PMMA will not cause wear/damage to the probes. If there is evidence of wear/damage on a probe, then this is likely to be caused by the probe making contact with either the bone or a metal obstruction (stem, screw, nail etc.)



If the probe heads contact bone, then an audible squeal [usually occurs and](#) provides feedback to the user. The user should immediately redirect the probe head to avoid contact with bone. Sometimes the audible response may be damped out when the bone cavity is still densely packed with bone cement, or the user may not be able to hear the very high pitch of the audible feedback from the probe head on bone.

[The squeal cannot be guaranteed as it is affected by the bone and cement properties as well as the probe angle, force and damping.](#) If a TORS Piercer probe appears to be silent but NOT moving forward through material, or making smoke, then it may well be contacting bone. DO NOT CONTINUE TO PUSH without checking where the probe is. Real time X-ray is very effective at this point.

Turn Off TORS

- Press the black ON/OFF power switch at the rear of the unit. The screen will become entirely black.



Fault / Warning Indicators: (see also Appendix 5: Tones and Beeps)



 <p>The Illuminated yellow triangle indicates that a fault has occurred.</p>	<p>It will always be accompanied by:</p>	
	<p>i. An illuminated symbol indicating the part of the equipment where the fault has occurred</p>	
	<p>ii. Illuminated text instructing the user e.g. Reduce Pressure</p>	
	<p>If warning relates to time, the clock symbol also illuminates</p>	
	<p>If warning is temperature related the temp symbol also illuminates</p>	

	<ul style="list-style-type: none"> • Too much force is being applied to the TDCR during activation. Reduce applied force to improve performance. Excessive force applied during activation can impede cutting performance. • No transducer connection. • Probe tip is too hot. Allow probe tip to cool.
---	--

	<p>Handpiece button or footswitch held in. A high-low tone will sound.</p>
---	--

	<p>Generator has over-heated. Check air vent below generator is unimpeded. A high-low tone will sound. Try again after 5- 10s.</p>
---	--

 +  + 	<p>The generator has detected a problem with the connections to the transducer. The warning triangle will illuminate and a triple high-high-high tone will sound and repeat. Switch OFF then ON to clear fault. Re-activate the transducer away from the patient – if fault recurs then change the transducer and return for service.</p> <p>ARCHIVED COPY:</p> <p>DO NOT USE</p>
---	---

 + 	<p>The Generator has detected a problem. The warning triangle will illuminate and a triple high-high-high tone will sound and repeat. Switch OFF then ON to clear fault. Switch generator back on – if fault recurs then return the system for service.</p>
---	---

DECONTAMINATION

In order to replicate the validated decontamination and sterilization processes for the TORS device, Sterilization and Decontamination Units must operate procedures and equipment that conform to ISO 17665-1. Validation of the sterilization process has been completed for steam autoclave cycles with an active phase of 3 minutes at 134°C.

Please refer to the separate Decontamination Certificate and Instruction (WIG0006 App1) provided with the Instrument Kit; this document provides all of the details for each of the following subjects:

- **After Use Re-Processing**

Immediately after use wipe down all components and remove any surplus body fluids and debris.

After final use some of the cement may remain adhered to the probe distal end, particularly within holes in the Piercer probe heads. This is easily removed by activating the probe in a suspension of fine abrasive grit in water. This is provided with the TORS system in the form of a single use cleaning cell.

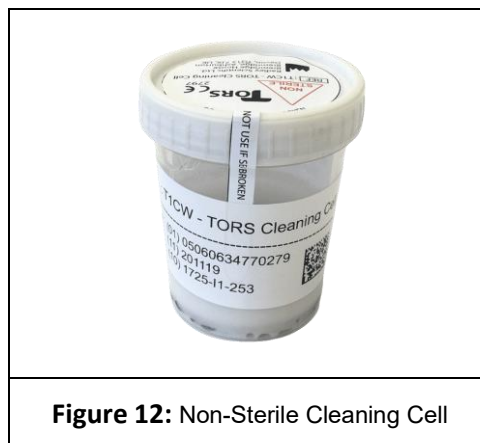

IMPORTANT: The cleaning cell is NOT sterile.
NOT for use DURING procedure
ONLY use at the end of the procedure prior to washing and re-sterilization
of reusable probes

Unscrew the cleaning cell lid and pierce the foil seal with the first probe. Activate each used probe in turn in the grit/water suspension in the cleaning cell, swirling the head around in the suspension for 20s. at least. Repeat, necessary. This will remove cement adhered to the surfaces.

Detach the Cement Cable(s) from the Cement Transducer(s) by disconnecting from the handpiece.

Remove the Sleeve from the Grip on the Cement Handpiece. Detach the Handpiece from the Cement Transducer by pulling the Transducer and the Handpiece apart.

Detach the Cement probe from the Cement Transducer using BOTH supplied spanners.

Replace the Transducers, Cables, Reusable Probes and spanners back into the autoclave tray, preferably within its original wrap to reduce drying of soil while it is returned to the cleaning facility.

ARCHIVED COPY:
DO NOT USE

- **Single Use Items**

Dispose of the Cement Handpiece Grip and Sleeve and the Cleaning Cell as per hospital protocols.

- **Reusable Items**

- **Manual Cleaning**

Prepare enzymatic cleaning solution (e.g. Gigazyme Plus) to manufacturer's instructions.

Soak soiled instruments in enzymatic solution for 5 minutes.

When cleaning, fully submerge the instruments in the cleaning solution. Brush with soft non-metallic bristle brush or cloth to remove all traces of blood and debris, concentrating on any crevices, seams, or other surface discontinuities. Clean holes and recesses using an appropriate brush ensuring that the full depth of the feature is reached. Ensure instruments are visibly clean before progressing to the next step.

Rinse instruments thoroughly with clean running water for 2 minutes. Ensure that blind holes and recesses are repeatedly filled and emptied with running water.

Dry instruments immediately after final rinse. Do not exceed 140°C (285°F)

- **Automated Cleaning**

Instruments may require manual cleaning prior to automated cleaning to improve the removal of adherent soil. Brush with a non-metallic bristle brush in enzymatic cleaning solution.

Load instruments such that crevices, seams, surface discontinuities, holes and recesses can drain.

Clean using the "Instruments" cycle in a validated washer disinfectant and a pH neutral cleaning agent intended for use in automatic cleaning (e.g. Getinge Enzymatic Detergent). The cleaning cycle should incorporate pre-rinse, wash, rinse, thermal rinse and drying steps. The duration and temperature of the steps may vary between different washing systems/devices but any washer/disinfectant cycle which is validated to ISO 15583-1, ISO 15883-2 & HTM 01-01 part D is suitable for processing the TORS device(s). Do not exceed 140°C (285°F).

An alkaline cleaning solution such as, for example, Serchem pH Plus Detergent, with a pH up to 13.2 may be used instead of, or in addition to, an enzymatic solution.

- **Cleaning Inspection**

Inspect all instruments prior to sterilization or storage to ensure the complete removal of soiled surfaces.

Visually inspect instruments, if soil is still present clean instruments again.

Inspect cables for wear and damage, ensuring that no cracks, tears, or other damage is found.

Check to see that Probes are free of scratches.

Report any damage found to the supplier/distributor representative.

- **Wrapping**

Double wrap in accordance with local procedures, using standard procedures wrapping techniques such as those described in HTM 01-01 or ANSI/AAMI ST46-1993.

Label contents of wrapped tray using indelible marker or other sterilization compatible label system.

- **Sterilization**

Sterilization is best achieved on the day preceding the surgery, but must be at least one hour prior to use to allow the equipment to cool and stabilize.

⚠ Transducers are NOT to be submerged in water to expedite cooling.

⚠ Do NOT sterilize the Generator or Footswitches

These components have been validated for sterilization by the following method in a vacuum autoclave. The parameters for this being 134-137°C (270°- 277°F) for a minimum of 3 and a maximum of 4 minutes. (If national standards dictate autoclaving up to 48 minutes, this is possible but not preferable.)

Next Use - After decontamination, the Transducers, Cement cables, probes and spanners can be re-sterilized as above.

- **End of Life Management**

TORS generator and all reusable accessories (including Transducers) should be recycled. Contact RSL for return instructions - see end page of this IFU.

A valid decontamination certificate MUST accompany any returned reusable accessories.

- **Opened in Error**

In the event of a Single Use Handpiece being unwrapped in error, it may not be re-sterilized.

Care should be taken to ensure that the cables are not kinked during sterilization as this can produce cracks in the cable and reduce cable life.

- **Cleaning the Generator**

The TORS Generator may be cleaned as follows:

- i. Dilute a neutral pH detergent according to the manufacturer's directions.
- ii. Using above solution, lightly moisten a soft, clean cloth. Wipe surfaces of the Generator.
- iii. Using tap water, lightly moisten a soft, clean cloth. Wipe surfaces of the Generator.
- iv. Dry Generator surfaces with a soft clean cloth.

- **Cleaning the Footswitch**

The TORS Footswitches may be cleaned as follows:

- i. Dilute a neutral pH detergent according to the manufacturer's directions.
- ii. Using above solution, lightly moisten a soft, clean cloth. Wipe surfaces of the Footswitch.
- iii. Using tap water, lightly moisten a soft, clean cloth. Wipe surfaces of the Footswitch.
- iv. Dry Footswitch surfaces with a soft clean cloth.
- v. Do not allow any water to enter into the air-hoses.
- vi. Do not detach the air hoses from the Footswitch.

Equipment Care

Probe Inspection

Before use all reusable Probes must be inspected for damage.

TORS probes are susceptible to damage if forced into contact with metal (e.g. hand instruments and clamps) when active. The consequence of deformation or scratching a probe is to raise the mechanical stress in the region of the scratch (creating a "stress raiser") when the probe is vibrating. If the stress is raised sufficiently there is a risk of the probe suffering metal fatigue and cracking. Fatigue failure is more likely if the stress raiser is close to one of the fixed points of maximum mechanical stress in the vibrating probe. If a probe does suffer metal fatigue as a result of a stress raiser causing a crack, the probe will no longer possess a resonant frequency "recognizable" by the generator and cannot be activated by the generator. Report to the supplier any transducer with a probe that has a scratch, if the scratch is deep enough to be detected by sliding a fingernail over it.

Transducer / Probe Usage

The cement transducers plus the cement probes of TORS can be decontaminated and reused. This is an important factor in reducing the cost per case. However, they cannot be reused indefinitely as probes will wear and the piezo crystals in transducers will depolarize over time and so service lifetimes are defined within which optimum performance can be expected. Therefore, probes and transducers must be replaced when needed.

The cement transducer lifetime is not limited by the system as its usage time is not monitored by the generator. It should be changed if cutting performance deteriorates. As a guide it may be changed after an average service life of 10 minutes ON-time per case, over 25 cases = 250 minutes ON-time.

All Cement Probes can be used for as long as they continue to soften and remove PMMA effectively as their usage time cannot be monitored by the generator. They should be changed if cutting performance deteriorates. As a guide they may be changed after an average service life of [one year](#).

Storage of Equipment between Cases

It is recommended that the transducers (with associated cables) are stored, between cases, in [the](#) large autoclave tray provided and again, care should be taken to ensure that the cables are not kinked close to the connector.

Maintenance

The hospital is responsible for ensuring that the unit has an electrical safety check performed by qualified service personnel at least once a year.

Do not remove the covers from TORS.

TORS generator does not require periodic calibration. If the generator detects an internal problem, it will display a "Service Due" on the rear LCD. If this is seen, contact RSL to arrange repair.

There are no user-serviceable parts in TORS.

Any damage to the transducers or cables should be reported and the components returned to the supplier at the earliest opportunity.

Technical Support

In line with the company's policy of quality assurance and customer care, RSL offers a telephone helpline service for users of TORS. This is provided by the TORS manufacturer, RSL at its facility in Devon, England.

[United Kingdom](#) HELPLINE Telephone No. as displayed on the unit is: +44 (0)7966 911670

APPENDICES

Appendix 1: TORS Accessory and Consumable Part Numbers

ARCH  COPY:

These accessories are all supplied in a **non-sterile condition** and are reusable. The end user must complete decontamination and sterilization processes before use/re-use.

DO NOT USE
Cement Transducer (Applied Part)

SKU



T1CT

Cement cable

SKU



T1CC









Short Extension Bars – straight and curved – 70 mm Length

SKU



ECR1

ESR1

<p style="text-align: center;">Spanner x2</p>	<p style="text-align: center;">SKU</p>
 <p style="text-align: right; font-size: 2em; font-weight: bold;">T1S</p>	<p style="text-align: center;">SKU</p> <p style="text-align: center; font-size: 1.5em; font-weight: bold;">T1S</p>
<p style="text-align: center;">Re-usable Cement Piercer Probes – 200 mm Length</p>	
	<p style="text-align: center;">SKU</p> <p style="text-align: center; font-weight: bold;">P4R2</p>
	<p style="text-align: center; font-weight: bold;">P6R2</p>
	<p style="text-align: center; font-weight: bold;">P8R2</p>
	<p style="text-align: center; font-weight: bold;">P10R2</p>
<p style="text-align: center;">Re-usable Cement Scraper Probes – 200 mm Length</p>	
	<p style="text-align: center; font-weight: bold;">S6R2</p>
	<p style="text-align: center; font-weight: bold;">S8R2</p>
	<p style="text-align: center; font-weight: bold;">S10R2</p>
<div style="text-align: center;">  <p style="font-weight: bold; margin-top: 10px;">These accessories are all supplied in a non-sterile condition and are reusable. The end user must complete decontamination and sterilization processes before use/re-use.</p> </div>	
<p style="text-align: center;">Figure 13: Patient contacting parts that must be sterilized before use</p>	

Supplied sterile (ethylene oxide)
DO NOT USE IF PACKAGING HAS BEEN DAMAGED!



STERILE EO

ARCHIVED COPY:
Single-Use Cement Axial Grip Handpiece

SKU



T1AH

Figure 14: Patient contacting part that is supplied sterile



This consumable is supplied in a **non-sterile condition** and is single use.

Single-Use Cleaning Cell

SKU



T1CW

Figure 15: Non-patient contacting part that is non-sterile

OPTIONAL EXTRAS

ARCHI  COPY:

These accessories are all supplied in a **non-sterile condition** and are reusable. The end user must complete decontamination and sterilization processes before use/re-use.

DO NOT USE

Re-usable Cement Piercer Probes – 200 mm Length

SKU



P12R2



P14R2

Re-usable Cement Scraper Probes – 200 mm Length

SKU



S12R2



S14R2

Re-usable Cement Piercer Probes – 100 mm Length

SKU



P6R1



P8R1











P10R1



P12R1



P14R1





<p>Re-usable Cement Scraper Probes – 100 mm Length</p>	<p>SKU</p>
	<p>S6R1</p>
	<p>S8R1</p>
	<p>S10R1</p>
	<p>S12R1</p>
	<p>S14R1</p>
<p>Re-usable Cement Chisel Probe – 100 mm Length</p>	<p>SKU</p>
	<p>C6R1</p>
	
<p>Long Extension Bar – straight and curved – 140 mm Length</p>	<p>SKU</p>
	<p>ESR2</p>
<div style="text-align: center;">  <p>NON STERILE</p> </div> <p>These accessories are all supplied in a non-sterile condition and are reusable. The end user must complete decontamination and sterilization processes before use/re-use.</p>	
<p>Figure 16: Patient contacting parts that must be sterilized before use</p>	

ITEM	Product Code	UDI-DI (GTIN)
TORS 1 complete system	T1	05060634770361
Generator	T1G	05060634770002
Mains Power Cordset	MPC	05060634771016
Generator Carry Case	T1GC	05060634770040
Cement Foot Switch	T1FC	05060634770019
Autoclave Tray	T1AT	05060634770095
Autoclave Tray Mat	T1SM	05060634770101
Instrument Carry Case	T1IC	05060634770118
Cement Transducer (Reusable)	T1CT	05060634770064
Cement Cable (Reusable)	T1CC	05060634770071
Cement 100mm Ø6mm Piercer Probe (Reusable)	P6R1	05060634770927
Cement 100mm Ø8mm Piercer Probe (Reusable)	P8R1	05060634770934
Cement 100mm Ø10mm Piercer Probe (Reusable)	P10R1	
Cement 100mm Ø12mm Piercer Probe (Reusable)	P12R1	05060634771238
Cement 100mm Ø14mm Piercer Probe (Reusable)	P14R1	05060634771252
Cement 200mm Ø4mm Piercer Probe (Reusable)	P4R2	05060634770729
Cement 200mm Ø6mm Piercer Probe (Reusable)	P6R2	05060634770736
Cement 200mm Ø8mm Piercer Probe (Reusable)	P8R2	05060634770743
Cement 200mm Ø10mm Piercer Probe (Reusable)	P10R2	05060634770750
Cement 200mm Ø12mm Piercer Probe (Reusable)	P12R2	05060634771214
Cement 200mm Ø14mm Piercer Probe (Reusable)	P14R2	05060634771221
Cement 100mm Ø6mm Scraper Probe (Reusable)	S6R1	05060634770941
Cement 100mm Ø8mm Scraper Probe (Reusable)	S8R1	05060634771047
Cement 100mm Ø10mm Scraper Probe (Reusable)	S10R1	
Cement 100mm Ø12mm Scraper Probe (Reusable)	S12R1	05060634771191
Cement 100mm Ø14mm Scraper Probe (Reusable)	S14R1	05060634771207
Cement 200 Ø6 Scraper Probe (Reusable)	S6R2	05060634770767
Cement 200 Ø8 Scraper Probe (Reusable)	S8R2	05060634770774
Cement 200 Ø10 Scraper Probe (Reusable)	S10R2	05060634770781
Cement 200mm Ø12mm Scraper Probe (Reusable)	S12R2	05060634771245
Cement 200mm Ø14mm Scraper Probe (Reusable)	S14R2	05060634771269
Cement 100mm 6mm Chisel Probe (Reusable)	C6R1	05060634771054
Probe Extension Bar - Long - Straight (Reusable)	ESR2	05060634770972
Probe Extension Bar - Straight (Reusable)	ESR1	05060634770989
Probe Extension Bar - Curved (Reusable)	ECR1	05060634770996
Spanner	T1S	05060634770354
Cement Axial Grip Handpiece (Single Use)	T1AH	05060634770323
Probe Cleaning Cell	T1CW	05060634770279

Appendix 2: Markings on the TORS front and back panels

	Cement transducer selected
	Cement transducer output - Channel 1
	Cement transducer output - Channel 2
	Transducer active
	Model number
	Serial number
	Manufacturer
	Date of manufacture
	FUSE rating – Time delay, 5A, High breaking capacity, 250 Volts AC, size 20mm
100-240V	Mains AC voltage range
	Alternating current
50/60Hz	Mains AC frequency
200VA	Input power
	Warning sign
	Type BF equipment
36kHz	Cement frequency of output
<150W	Cement output power
For Intermittent Use ON/OFF 20/20s	Cement duty cycle
	Volume
	Footswitch connection





ARCHIVED COPY:
DO NOT USE





	Equipotential connection
	Output channel
	Follow instructions for use
	Electrical and Electronic equipment. Return waste to a collection system or treatment and recycling facilities. Follow decontamination instructions before returning waste.
	General caution sign

ARCHIVED COPY:





DO NOT USE

Appendix 3: Labelling Symbols Glossary

Symbol	Standard	Ref #	Title	Description
	ISO 15223-1 Medical devices — Symbols to be used with information to be supplied by the manufacturer	5.1.1	Manufacturer	Indicates the medical device manufacturer
	ISO 15223-1 Medical devices — Symbols to be used with information to be supplied by the manufacturer	5.1.2	Authorized representative in the European Community/ European Union	Indicates the authorized representative in the European Community/ European Union
	ISO 15223-1 Medical devices — Symbols to be used with information to be supplied by the manufacturer	5.1.3	Date of manufacture	Indicates the date when the medical device was manufactured
	ISO 15223-1 Medical devices — Symbols to be used with information to be supplied by the manufacturer	Permitted by standard	Country of manufacture	Used in place of 5.1.3 and will have date of manufacture nearby. Indicates that the product was manufactured in Great Britain (also known as the UK or United Kingdom of Great Britain and Northern Ireland)

	<p>ISO 15223-1 Medical devices — Symbols to be used with information to be supplied by the manufacturer</p>	<p>5.1.4</p>	<p>Use-by date</p>	<p>Indicates the date after which the medical device is not to be used</p>
	<p>ISO 15223-1 Medical devices — Symbols to be used with information to be supplied by the manufacturer</p>	<p>5.1.5</p>	<p>Batch code</p>	<p>Indicates the manufacturer's batch code so that the batch or lot can be identified</p>
	<p>ISO 15223-1 Medical devices — Symbols to be used with information to be supplied by the manufacturer</p>	<p>5.1.6</p>	<p>Catalogue number</p>	<p>Indicates the manufacturer's catalogue number so that the medical device can be identified.</p>
	<p>ISO 15223-1 Medical devices — Symbols to be used with information to be supplied by the manufacturer</p>	<p>5.1.7</p>	<p>Serial number</p>	<p>Indicates the manufacturer's serial number so that a specific medical device can be identified</p>
	<p>ISO 15223-1 Medical devices — Symbols to be used with information to be supplied by the manufacturer</p>	<p>5.1.8</p>	<p>Importer</p>	<p>Indicates the entity importing the medical device into the locale</p>

**CHIVED COPY:
DO NOT USE**

	<p>ISO 15223-1 Medical devices — Symbols to be used with information to be supplied by the manufacturer</p>	<p>5.1.9</p>	<p>Distributor</p>	<p>Indicates the entity distributing the medical device into the locale</p>
	<p>ISO 15223-1 Medical devices — Symbols to be used with information to be supplied by the manufacturer</p>	<p>5.2.3</p>	<p>Sterilized using ethylene oxide</p>	<p>Indicates a medical device that has been sterilized using ethylene oxide.</p>
	<p>ISO 15223-1 Medical devices — Symbols to be used with information to be supplied by the manufacturer</p>	<p>5.2.7</p>	<p>Non-sterile</p>	<p>Indicates a medical device that has not been subjected to a sterilization process</p>
	<p>ISO 15223-1 Medical devices — Symbols to be used with information to be supplied by the manufacturer</p>	<p>5.2.8</p>	<p>Do not use if package is damaged and consult instructions for use</p>	<p>Indicates a medical device that should not be used if the package has been damaged or opened and that the user should consult the instructions for use for additional information.</p>
	<p>ISO 15223-1 Medical devices — Symbols to be used with information to be supplied by the manufacturer</p>	<p>5.2.14</p>	<p>Single sterile barrier system with protective packaging outside</p>	<p>Indicates a single sterile barrier system with protective packaging outside</p>



ISO 15223-1
Medical devices
— Symbols to
be used with
information to
be supplied by
the
manufacturer

Permitted
by
standard

Combines 5.2.3
and 5.2.14 (As
permitted by ISO
15223-1) to
indicate that the
device is
sterilized by
ethylene oxide
and has a single
sterile barrier with
protective
packaging
outside

**ARCHIVED COPY:
DO NOT USE**



ISO 15223-1
Medical devices
— Symbols to
be used with
information to
be supplied by
the
manufacturer

5.3.4

Keep dry

Indicates a
medical device
that needs to be
protected from
moisture.

NOTE: This
symbol indicates
that the
packaging must
be kept dry to
maintain the
integrity of the
packaging
material. The
device itself is
designed for use
in wet or fluid-
filled
environments and
is not affected by
moisture.







ISO 15223-1
Medical devices
— Symbols to
be used with
information to
be supplied by
the
manufacturer

5.3.7





Temperature
limit





Indicates the
temperature limits
to which the
medical device
can be safely
exposed.

	<p>ISO 15223-1 Medical devices — Symbols to be used with information to be supplied by the manufacturer</p>	<p>5.3.8</p>	<p>Humidity limitation</p>	<p>Indicates the range of humidity to which the medical device can be safely exposed.</p>
	<p>ISO 15223-1 Medical devices — Symbols to be used with information to be supplied by the manufacturer</p>	<p>5.4.2</p>	<p>Do not re-use/ Single use only</p>	<p>Indicates a medical device that is intended for one single use only.</p>
	<p>ISO 15223-1 Medical devices — Symbols to be used with information to be supplied by the manufacturer</p>	<p>5.4.3</p>	<p>Consult instructions for use</p>	<p>Indicates the need for the user to consult the instructions for use.</p>
	<p>ISO 15223-1 Medical devices — Symbols to be used with information to be supplied by the manufacturer</p>	<p>5.4.4</p>	<p>Caution</p>	<p>Indicates the need for the user to consult the instructions for use for important cautionary information such as warnings and precautions that cannot, for a variety of reasons, be presented on the medical device itself.</p>

**ARCHIVED COPY:
DO NOT USE**

ARCHIVED COPY:

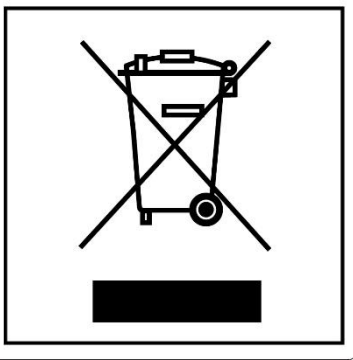
	<p>ISO 15223-1 Medical devices — Symbols to be used with information to be supplied by the manufacturer</p>	<p>5.7.7</p>	<p>Medical Device</p>	<p>Indicates the item is a medical device.</p>
	<p>ISO 15223-1 Medical devices — Symbols to be used with information to be supplied by the manufacturer</p>	<p>5.7.10</p>	<p>Unique Device Identifier</p>	<p>Indicates a carrier that contains Unique Device Identifier information.</p>
	<p>ISO 7010-M002, IEC 60601-1, Table D.2, Symbol 10</p>		<p>Follow instructions for use or follow electronic instructions for use.</p>	<p>Follow instructions for use.</p>
	<p>MDD 93/42/EEC MDR 2017/745 Regulation (EC) 765/2008</p>	<p>Annex XII Article 20 Annex II</p>	<p>CE marking, may include Notified Body Reference no. 2797</p>	<p>Signifies European technical conformity.</p>
				<p>Signifies UKCA technical conformity</p>

<p>R_x only</p>	<p>21 CFR 801.15 21 CFR 801.109</p>	<p>(c) (1) (i) (F) (b) (1)</p>	<p>Prescription only</p>	<p>Caution: Federal (US) law restricts this device to sale by or on the order of a physician.</p>
<p>IFU indicator</p> 	<p>21 CFR 801.109 Medical devices — Symbols to be used with information to be supplied by the manufacturer</p>	<p>A.16</p>	<p>Consult instructions for use or consult electronic instructions for use</p>	
				<p>Global Trade Item Number</p>
	<p>Directive 2002/96/ EC (repealed). Replaced by DIRECTIVE 2012/19/EU which does NOT contain this symbol.</p>		<p>Waste stream disposal status</p>	<p>Do not dispose of electronic products in the general waste stream</p>
	<p>DIRECTIVE 2012/19/ EU (WEEE)</p>	<p>Annex IX</p>	<p>Collect separately</p>	<p>indicating separate collection for EEE</p>
 <p>800526</p>				<p>SGS North America Certification Mark</p>

**ARCHIVED COPY:
DO NOT USE**

Appendix 4: Electromagnetic Interference

Table 1

Guidance and manufacturer's declaration – electromagnetic emissions			
TORS T1G is intended for use in the electromagnetic environment specified below. The customer or the user of TORS should assure that it is used in such an environment.			
Emissions Test	Compliance	Electromagnetic environment - guidance	
RF emissions CISPR 11		TORS uses RF energy only for its internal function. Therefore, its RF emissions are very low and are not likely to cause any interference in nearby electronic equipment.	
RF emissions CISPR 11	Class A		
Harmonic emissions IEC 61000-3-2	No testing – not connected to public mains network	TORS is suitable for use in all establishments other than domestic and those directly connected to the public low-voltage power supply network that supplies buildings used for domestic purposes.	
Voltage fluctuations /flicker emissions IEC 61000-3-3	No testing – not connected to public mains network		

Table 2

Guidance and manufacturer's declaration – electromagnetic immunity			
TORS is intended for use in the electromagnetic environment specified below. The customer or the user of TORS should assure that it is used in such an environment.			
IMMUNITY test	IEC 60601 test level	Compliance level	Electromagnetic environment - guidance
Electrostatic discharge (ESD) IEC 61000-4-2	±8 kV contact ±15 kV air	±6 kV contact ±8 kV air (1)	Floors should be conductive. No synthetic material should be used in the environment. The relative humidity should be in the range 40% to 60%.
Electrical fast transient/burst IEC61000-4-4	±2 kV for power supply lines	±2 kV for power supply lines	Mains power quality should be that of a typical commercial or hospital environment.
Surge IEC 61000-4-5	±1 kV differential mode ± 2 kV common mode	±1 kV differential mode ± 2 kV common mode	Mains power quality should be that of a typical commercial or hospital environment.
Voltage dips, short interruptions and voltage variations on power supply input lines IEC 61000-4-11	0 % U_T ⁽²⁾ (100 % dip in U_T) for 0.5 cycle at: 0°,45°,90°, 135°,180°,225°, 270°,315° 0 % U_T (100 % dip in U_T) for 1 cycles 70 % U_T (30 % dip in U_T) For 25/30 cycles 0 % U_T (100 % interrupt in U_T) for 250/300 cycles	0 % U_T (100 % dip in U_T) for 0.5 cycle at: 0°,45°,90°, 135°,180°,225°, 270°,315° 0 % U_T (100 % dip in U_T) for 1 cycles 70 % U_T (30 % dip in U_T) For 25/30 cycles 0 % U_T (100 % interrupt in U_T) for 250/300 cycles	Mains power quality should be that of a typical commercial or hospital environment. If the user of TORS requires continued operation during power mains interruptions, it is recommended that TORS be powered from an uninterruptible power supply.
Power frequency (50/60 Hz) magnetic field IEC61000-4-8	3 A/m	No testing	No magnetically sensitive components.
<p>NOTES:</p> <p>Mitigation applied because of environment.</p> <p>U_T is the a.c. mains voltage prior to application of the test level.</p>			

Table 3

Guidance and manufacturer's declaration – electromagnetic immunity			
TORS is intended for use in the electromagnetic environment specified below. The customer or the user of TORS should assure that it is used in such an environment.			
IMMUNITY test	IEC 60601 test level	Compliance level	Electromagnetic environment - guidance
Conducted RF IEC 61000-4-6	3V rms 150kHz to 80 MHz Outside ISM bands	3V rms	Portable and mobile RF communications equipment should be used no closer to any part of TORS, including cables, than the recommended separation distance calculated from the equation applicable to the frequency of the transmitter. Recommended separation distance $d = 1.2\sqrt{P}$, 150 kHz to 80 MHz $d = 1.2\sqrt{P}$, 80MHz to 800MHz $d = 2.3\sqrt{P}$, 800MHz to 2.3GHz
Radiated RF IEC 61000-4-3	6V rms In ISM bands 0.15MHz to 80MHz 80% AM at 1kHz	6V rms	where P is the maximum power output rating of the transmitter in watts (W) according to the transmitter manufacturer and d is the recommended separation distance in metres (m).
Immunity to proximity fields from RF wireless communications equipment	3 V/m 80MHz to 2.5GHz	3 V/m	Field strengths from fixed RF transmitters, as determined by an electromagnetic site survey, ^a should be less than the compliance level in each frequency range. ^b
	9 V/m 710MHz, 745MHz, 780MHz, 5240MHz, 5500MHz, 5785MHz	9V/m	Interference may occur in the vicinity of equipment marked with the following symbol.
	27 V/m 385MHz	27V/m	
	28 V/m 450MHz, 810MHz, 870MHz, 930MHz, 1720MHz, 1845MHz, 1970MHz, 2450MHz	28V/m	
NOTE 1 At 80 MHz and 800 MHz, the higher frequency range applies			
NOTE 2 These guidelines may not apply in all situations. Electromagnetic propagation is affected by absorption and reflection from structures, objects and people.			
<p><i>a Field strength from fixed transmitters, such as base stations for radio (cellular/cordless) telephones and land mobile radios, amateur radio, AM and FM radio broadcast and TV broadcast cannot be predicted theoretically with accuracy. To assess the electromagnetic environment due to fixed RF transmitters, an electromagnetic site survey should be considered. If the measured field strength in the in the location in which TORS is used exceed the applicable RF compliance level above, TORS should be observed to verify normal operation. If abnormal performance is observed, additional measures may be necessary, such as re-orienting or relocating TORS.</i></p>			
<p><i>b Over the frequency range 150 kHz to 80 MHz, field strengths should be less than 3 V/m</i></p>			

ARCHIVED COPY:
DO NOT USE

Table 4

Recommended separation distances between portable and mobile RF communications equipment and TORS			
TORS is intended for use in an electromagnetic environment in which radiated RF disturbances are controlled. The customer or the user of TORS can help prevent electromagnetic interference by maintaining a minimum distance between portable and mobile RF communications equipment and TORS as recommended below, according to the maximum output power of the communications equipment.			
Rated maximum output power of transmitter	Separation distance according to frequency of transmitter		
	150 kHz to 80 MHz	80 MHz to 800 MHz	800MHz to 2.5 GHz
	$d = 1.2\sqrt{P}$	$d = 1.2\sqrt{P}$	$d = 2.3\sqrt{P}$
0.01	0.12	0.12	0.23
0.1	0.38	0.38	0.73
1	1.2	1.2	2.3
10	3.8	3.8	7.3
100	12	12	23
<p>For transmitters rated at a maximum output power not listed above, the recommended separation distance d in metres (m) can be estimated using the equation applicable to the frequency of the transmitter, where P is the maximum output power rating of the transmitter in watts (W) according to the transmitter manufacturer.</p> <p>NOTE 1 At 80 MHz and 800 MHz, the higher frequency range applies</p> <p>NOTE 2 These guidelines may not apply in all situations. Electromagnetic propagation is affected by absorption and reflection from structures, objects and people.</p>			

ARCHIVED COPY:
DO NOT USE

Appendix 5: Tones and Beeps

Rising flourish	TORS is booting to standby mode
No Tone	TORS is in standby mode
Triple tone – low-medium-low pitch	Handpiece activate button has been pressed to initialize handpiece (cement)
Continuous low pitched tone	Acoustic output for the cement transducer
Double beep –high>low pitch	The Generator has reset itself after a minor problem such as time-out or over-temperature but the most common event is frequency mis-tuning due to probe over-damping. So, generally this tone means: "Over-loaded probe, reduce pressure and try again"
Triple beep – high>high>high pitch	A more serious problem has been detected.

Appendix 6: Rear Panel Messages

The LCD on the rear panel will display messages that indicate the status of the equipment. The following table shows the possible displays:

Message	Status	Action required
Radley Scientific Ltd TORS Issue x	Start up message. Shows the Issue number of the software.	Now awaiting transducer to be plugged in
Cement Ready	The toggle switch has been operated and the transducer is ready to be activated.	Now awaiting use
36000Hz Cement Active	While transducer is active the top line will show the frequency. After releasing the switch it will display the final running frequency.	No action required
Active Too long Release Switches	The active button has been held on for too long. No output.	Release activate button on handpiece or on footswitch
Release Switches	Either activate or toggle button (or Footswitches) has been pressed a switch on.	Release activate or toggle button when switching on generator
Check Transducer Ease Grip and Retry	Transducer has been loaded too heavily	Release switch, then reactivate using less pressure on the jaw
	Transducer is too hot.	Allow transducer to cool.
Change Transducer Restart	Transducer frequency too low and feedback signal is low.	Switch supply off & on. Replace transducer if seen 3 times.
Transducer Leakage Change Tdcr	Generator has detected voltage on the transducer.	
Frequency Error Service due	The generator has detected a serious internal problem.	Switch supply off & on. If message seen again generator requires service.

Appendix 7: Technical Specification

Model Nos:	See Appendix 1
Dimensions:	Generator: 340 mm (width) x 95 mm (height) x375 mm (depth) 13.4" (width) x 3.7" (height) x 13.4" (depth)
Weight:	Generator: 7.6 kg Transport case: 13.8 kg (loaded with generator) Transducer: 0.37 kg
Fuse Type:	T5A, 250 V, 20 mm (2 off)
Cordset	Contact RSL for recommended type
Power supply input	100V – 240 V, 50/60 Hz
Power consumption	200 VA
Cement Output - Frequency of operation	36k Hz
Cement Output – Power	<150 W
Cement Mode of Operation	Intermittent ON/OFF, 20/20 s
Cement Transducer Classification:	Type BF
Insulation Classification	Generator: Class 1
Transducer	Titanium, stainless steel, and plastic. Autoclavable maximum 50 cycles for the Cement Transducer.
Environment for Transportation & Storage: (Except T1AH – Sterile Handpiece)	Temperature: -10°C to +50°C Relative humidity: 10% to 90% Atmospheric pressure: 50 kPa to 106 kPa
Environment for Storage of T1AH Sterile Handpiece:	Temperature: +10°C to +35°C Relative humidity: 30% to 50% Atmospheric pressure: 50 kPa to 106 kPa
Environment for Use:	Temperature: +10°C to +30°C Relative humidity: 30% to 75% Atmospheric pressure: 81 kPa to 106 kPa

TORS has been designed and built-in accordance with ISO 13485: 2016 Quality Assurance standard for medical devices.

CE conformance has been certified and the equipment complies with:

IEC 60601-1:2005 + CORR. 1:2006 + CORR.2:2007 + A1:2012

Appendix 8: Warranty Statement

Subject to the terms and conditions listed in the warranty document (available on request) Radley Scientific Ltd. guarantees to replace or repair free of charge any defective parts of TORs notified within the warranty period. This applies to the hardware associated with TORs 1 for the purpose of warranty claims made by any party supplied directly by the Company or its authorized representative.

DO NOT USE

ARCI COPY:
DO NOT USE

CE
2797

UK
CA
0086



Bremridge House,
Bremridge,
Ashburton
S. Devon
TQ13 7JX
UK

Tel: +44 (0)7966 911670 – Helpline

www.tors.co.uk

endocon GmbH
In der Au 5
Wiesenbach
69257
Germany

Effectum CH-REP AG
Kirchgasse 11
CH-4600 Olten